

TF4

In-Tank Filter Assembly

Ideal for installation on the return line to remove contaminant ingested or generated by the system.

Max Operating Pressure: 100 psi (6.9 bar)



hyprofiltration.com/



Elements that go beyond industry standard.

Hy-Pro's DFE rated G8 dualglass elements are rated to assure performance even when exposed to the toughest conditions that hydraulic systems can generate. Designed to provide the best filtration and ease of use, the HP4C coreless element gives you more options for disposal, meaning you improve your environmental impact **and** your bottom line.



Works with your system.

Available with one or two inlet ports (180° orientation) for maximum flexibility of installation, you'll be amazed at how easily the TF4 integrates into your system. For applications requiring AIAG HF4 automotive standards compliance, the H4 special option incorporates the HPK filter element to ensure you meet compatibility requirements and exceed efficiency expectations.

Minimize the mess.

With most of the assembly inside the reservoir, the top loading housing on the TF4 provides easy and clean access when servicing or changing the element. To top it off, keyways on the twist open cover require only loosening of the bolts to access the element so lost parts during service becomes a thing of the past.



TF4 Installation Drawing

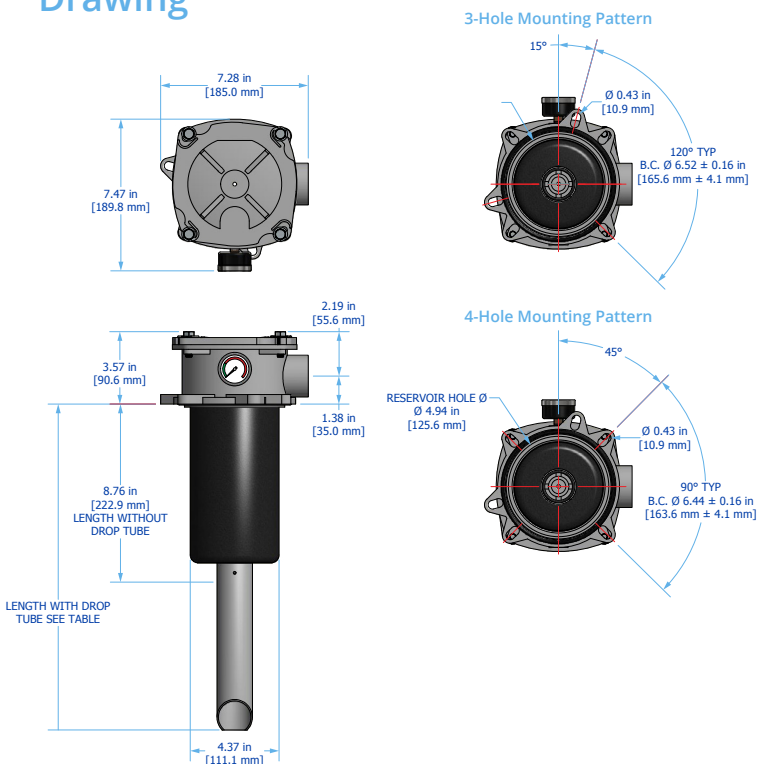

The perfect fit.

Coming in at just over 7" (185 mm) in diameter, the TF4 is the perfect compact solution for keeping your mobile equipment or power units operating at peak performance. And with mounting patterns to fit both North American and European formats, you'll get clean oil and increased efficiency no matter where you are.

Drop Tube Option	Length including Drop Tube
4" Nominal Extension	14.3" (363 mm)
6" Nominal Extension	16.3" (414 mm)
8" Nominal Extension	18.3" (465 mm)
9" Nominal Extension	19.3" (490 mm)
10" Nominal Extension	20.3" (516 mm)
12" Nominal Extension	22.3" (566 mm)

Filter Assembly Sizing

Filter Assembly Sizing Guidelines

Effective filter sizing requires consideration of flow rate, viscosity (operating and cold start), fluid type and degree of filtration. When properly sized, bypass during cold start can be avoided/minimized and optimum element efficiency and life achieved. The filter assembly differential pressure values provided for sizing differ for each media code, and assume 32 cSt (150 SUS) viscosity and 0.86 fluid specific gravity. Use the following steps to calculate clean element assembly pressure drop.

Calculate ΔP coefficient for actual viscosity

Using Saybolt Universal Seconds (SUS)

$$\Delta P \text{ Coefficient} = \frac{\text{Actual Operating Viscosity}^1 \text{ (SUS)}}{150} \times \frac{\text{Actual Specific Gravity}}{0.86}$$

Using Centistokes (cSt)

$$\Delta P \text{ Coefficient} = \frac{\text{Actual Operating Viscosity}^1 \text{ (cSt)}}{32} \times \frac{\text{Actual Specific Gravity}}{0.86}$$

Calculate actual clean filter assembly ΔP at both operating and cold start viscosity

$$\text{Actual Assembly Clean } \Delta P = \text{Flow Rate} \times \frac{\Delta P \text{ Coefficient (from calculation above)}}{\text{Assembly } \Delta P \text{ Factor (from sizing table)}}$$

Sizing recommendations to optimize performance and permit future flexibility

- To avoid or minimize bypass during cold start the actual assembly clean ΔP calculation should be repeated for start-up conditions if cold starts are frequent.
- Actual assembly clean ΔP should not exceed 10% of bypass ΔP gauge/indicator set point at normal operating viscosity.
- If suitable assembly size is approaching the upper limit of the recommended flow rate at the desired degree of filtration consider increasing the assembly to the next larger size if a finer degree of filtration might be preferred in the future. This practice allows the future flexibility to enhance fluid cleanliness without compromising clean ΔP or filter element life.
- Once a suitable filter assembly size is determined consider increasing the assembly to the next larger size to optimize filter element life and avoid bypass during cold start.
- When using water glycol or other specified synthetics we recommend increasing the filter assembly by 1~2 sizes.

TF4 Specifications

Dimensions See Installation Drawings on page 161 for model specific dimensions.

Operating Temperature	Fluid Temperature	Ambient Temperature
	30°F to 225°F (0°C to 105°C)	-4°F to 140°F (-20C to 60C)

Operating Pressure 100 psi (6.9 bar) maximum

Pressure Switch Trigger 22 psi (1.5 bar)

Element Collapse Rating	HP4CL9	HPKL9
	150 psid (10.3 bard)	290 psid (20 bard)

Integral Bypass Setting 25 psid (1.7 bard)

Materials of Construction	Head	Bowl
	Cast aluminum	Polyamide

Media Description	M	A	W
	G8 Dualglass, our latest generation of DFE rated, high performance glass media for all hydraulic & lubrication fluids. $\beta_{x_{[C]}} \geq 4000$	G8 Dualglass high performance media combined with water removal scrim. $\beta_{x_{[C]}} \geq 4000$	Stainless steel wire mesh media $\beta_{x_{[C]}} \geq 2$ ($\beta_x \geq 2$)

Replacement Elements To determine replacement elements, use corresponding codes from your assembly part number:

Configuration	Filter Element Part Number	Example
Standard Filter Element	HP4CL9 – [Media Selection Code] [Seal Code]	HP4CL9-10AV
Special Option H4	HPKL9 – [Media Selection Code] [Seal Code]	HPKL9-6MB

Fluid Compatibility Petroleum and mineral based fluids (standard). For polyol ester, phosphate ester, and other specified synthetic fluids use fluorocarbon seal option or contact factory.

Filter Sizing¹ Filter assembly clean element ΔP after actual viscosity correction should not exceed 10% of filter assembly bypass setting. See page 22 for filter assembly sizing guidelines & examples. For applications with extreme cold start condition contact Hy-Pro for sizing recommendations.

ΔP Factors ¹	Units	Media						
		1M	3M	6M	10M	16M	25M	**W
	psid/gpm	0.2370	0.2000	0.1550	0.1390	0.1360	0.1310	0.0240
	bard/lpm	0.0043	0.0036	0.0028	0.0025	0.0025	0.0024	0.0004

Max flow rates and ΔP factors assume $u = 150$ SUS, 32 cSt. See filter assembly sizing guideline for viscosity conversion formula on page 22 for viscosity change.



TF4 Part Number Builder

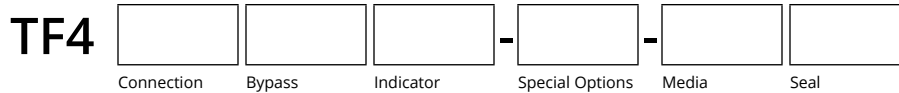

Connection	Port Option	Max Flow Rate
	G20 1.25" BSPT	40 gpm (151 lpm) ¹
	N20 1.25" NPT	40 gpm (151 lpm) ¹
	S20 1.25" SAE	40 gpm (151 lpm) ¹

Bypass	2 Integrated bypass - 25 psid (1.7 bard)
--------	---

Pressure Indicator	DX Electric pressure switch (DIN connection)
	E Electric switch with flying leads (3-wire connection)
	G Visual pressure gauge
	X No indicator (port plugged)

Special Options	D2 ² Dual inlet ports, 180° orientation
	H4 ³ HPK series element for automotive standards compatibility
	4 4" (10 cm) nominal drop tube extension
	6 6" (15 cm) nominal drop tube extension
	8 8" (20 cm) nominal drop tube extension
	9 9" (23 cm) nominal drop tube extension
	10 10" (25 cm) nominal drop tube extension
12 12" (30 cm) nominal drop tube extension	

Media Selection	G8 Dualglass	G8 Dualglass + water removal	Stainless wire mesh
	1M $\beta_{3, [C]} \geq 4000$	3A $\beta_{5, [C]} \geq 4000$	25W 25 μ nominal
	3M $\beta_{5, [C]} \geq 4000$	6A $\beta_{7, [C]} \geq 4000$	40W 40 μ nominal
	6M $\beta_{7, [C]} \geq 4000$	10A ³ $\beta_{12, [C]} \geq 4000$	74W 74 μ nominal
	10M ³ $\beta_{12, [C]} \geq 4000$	25A $\beta_{22, [C]} \geq 4000$	149W 149 μ nominal
	16M $\beta_{17, [C]} \geq 4000$		
	25M $\beta_{22, [C]} \geq 4000$		

Seals	B Nitrile (Buna)
	V Fluorocarbon
	E-WS EPR seals + stainless steel support mesh

¹Maximum recommended flow rate based on velocity through port and internal flow path. Consult sizing guidelines or consult factory for sizing based on flow rate, viscosity, temperature, filter media selection.

²Available with S4 port only.

³Replaces standard HP4C series element with HPKL9. Use 12M or 12A for respective media code in place of 10M or 10A.

For all up to date option details and compatibilities, please reference our [Contamination Solutions Price List](#) or contact customer service.



Filtration starts with the filter.

Lower ISO Codes: Lower Total Cost of Ownership Hy-Pro filter elements deliver lower operating ISO Codes so you know your fluids are always clean, meaning lower total cost of ownership and reducing element consumption, downtime, repairs, and efficiency losses.

DFE Rated Filter Elements DFE is Hy-Pro's proprietary testing process which extends ISO 16889 Multi Pass testing to include real world, dynamic conditions and ensures that our filter elements excel in your most demanding hydraulic and lube applications.

Upgrade Your Filtration Keeping fluids clean results in big reliability gains and upgrading to Hy-Pro filter elements is the first step to clean oil and improved efficiency.

Advanced Media Options DFE glass media maintaining efficiency to $\beta_{3, \mu} > 4000$, Dualglass + water removal media to remove free and emulsified water, stainless wire mesh for coarse filtration applications, and Dynafuzz stainless fiber media for EHC and aerospace applications.

Delivery in days, not weeks From a massive inventory of ready-to-ship filter elements to flexible manufacturing processes, Hy-Pro is equipped for incredibly fast response time to ensure you get your filter elements and protect your uptime.

More than just filtration Purchasing Hy-Pro filter elements means you not only get the best filters, you also get the unrivaled support, training, knowledge and expertise of the Hy-Pro team working shoulder-to-shoulder with you to eliminate fluid contamination.

Want to find out more? Get in touch.

hyprofiltration.com
info@hyprofiltration.com
+1 317 849 3535

© 2023 Hy-Pro Corporation. All rights reserved.



MKTLITFAS-TF4-051523-EM