

PFH840

High Pressure In-line Filter Assemblies

Hy-Pro's PFH pressure filters are designed to protect sensitive components in hydraulic circuits. Install the series upstream of specific components or directly after the pressure pump in smaller systems to minimize risk of failure and costly system downtime.

Ideal for use on a power unit pump discharge filter or pilot filter directly in front of valves and actuators.

Max Operating Pressure: 9137 psi (630 bar)



hyprofiltration.com/

Dynamic Filter Efficiency.

Hydraulic applications see dynamic flow changes on a regular basis. Dynamic Filter Efficiency testing takes the ISO 4409 Multi-Pass testing even further with variable flow shifts to ensure your filter elements stand up to real world conditions and maintain the highest capture and retention rates in the industry.

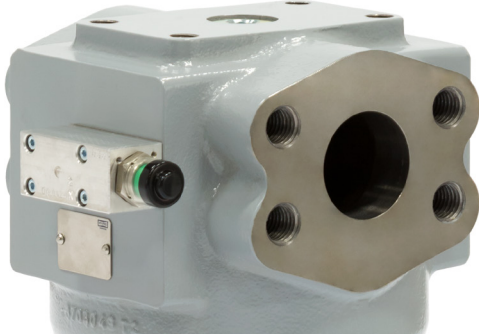
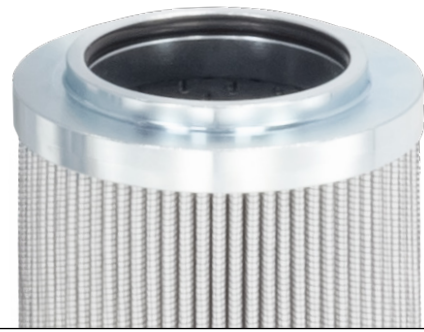

Industrial duty.

Standard mounting holes for optional brackets, stainless steel ID holes, a variety of indicator options, and standard drain ports make the PFH the ideal choice for heavy duty hydraulic filtration.

Unique applications.

With available nickel plating of internal components and coarse wire mesh media options, the PFH series is perfect for applications like drill rig mud pump and gearbox applications where water contamination wrecks traditional filtration. Even include Hy-Pro's G8 Dualglass media with Water Removal to take out dirt and water and leave your equipment operating more efficiently than ever.

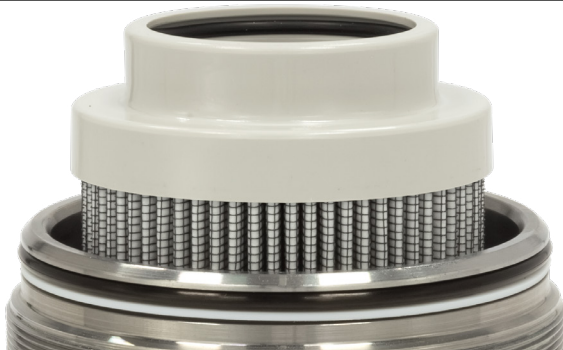
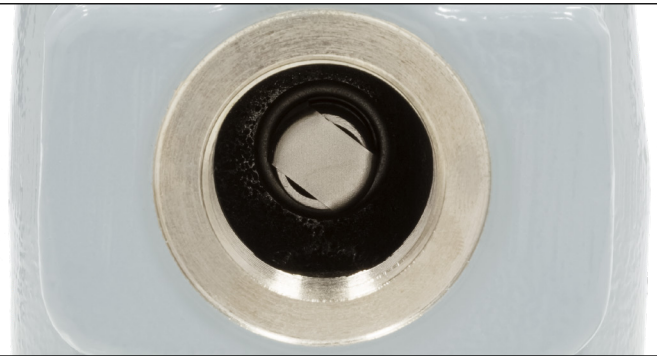

Minimize the mess.

The PFH series is available with Hy-Pro's coreless filter elements that can be readily disposed of through crushing or incineration. The circumferential o-ring bowl seal eliminates leaking and weeping. For easy cleaning and service, PFH bowls comes standard with drain plugs.

Extend the life of your element.

Unique internal flow paths provide low resistance to flow, resulting in a low housing pressure drop. Hy-Pro's advanced filter media delivers lower operating ISO Codes to eliminate internally generated contamination meaning your filter will have an incredibly long service life to protect your sensitive components better than ever.

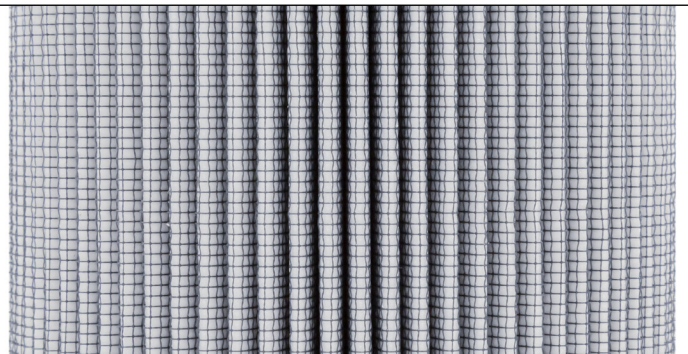

The ideal choice for hydraulics.

Use the PFH as the main high pressure filter(s) in a hydraulic system or upstream of sensitive components as a pilot filter to protect your valves and actuators. The PFH series are engineered to provide lower operating ISO Codes than what is required for compliance with hydraulic component manufacturers warranties.

PFH840 Reference Guide

PFH840 model shown

(4) 1/2" - 13 UNC mounting holes

Outlet

Δ P indicator

Assembly ID tag



Powder coated filter bowl

Bowl drain with removal cap for easy service

PFH840 Installation Drawings

Can be mounted as shown or inverted (bowl-up)

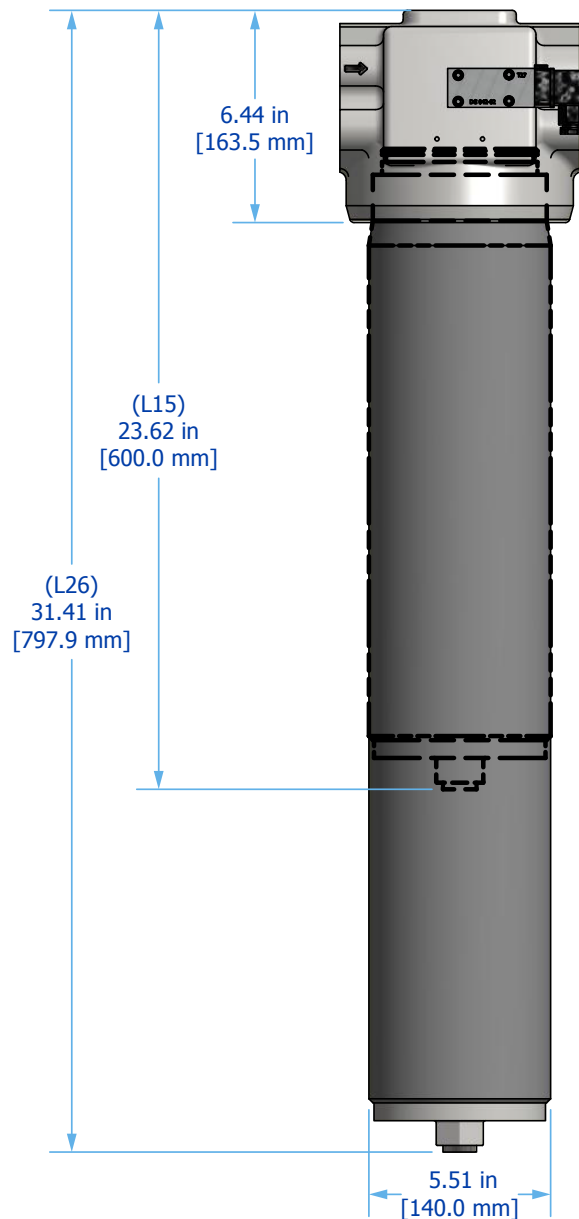
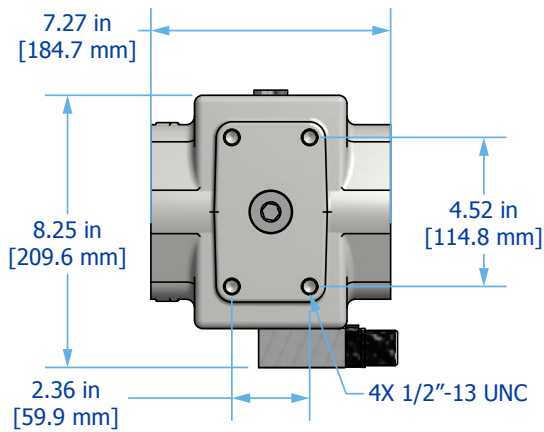

PFH840 Sizing Guidelines

Filter Assembly Sizing Guidelines

Effective filter sizing requires consideration of flow rate, viscosity (operating and cold start), fluid type and degree of filtration. When properly sized, bypass during cold start can be avoided/minimized and optimum element efficiency and life achieved. The filter assembly differential pressure values provided for sizing differ for each media code, and assume 32 cSt (150 SUS) viscosity and 0.86 fluid specific gravity. Use the following steps to calculate clean element assembly pressure drop.

Sizing recommendations to optimize performance and permit future flexibility

- To avoid or minimize bypass during cold start the actual assembly clean ΔP calculation should be repeated for start-up conditions if cold starts are frequent.
- Actual assembly clean ΔP should not exceed 10% of bypass ΔP gauge/indicator set point at normal operating viscosity.
- If suitable assembly size is approaching the upper limit of the recommended flow rate at the desired degree of filtration consider increasing the assembly to the next larger size if a finer degree of filtration might be preferred in the future. This practice allows the future flexibility to enhance fluid cleanliness without compromising clean ΔP or filter element life.
- Once a suitable filter assembly size is determined consider increasing the assembly to the next larger size to optimize filter element life and avoid bypass during cold start.
- When using water glycol or other specified synthetics, we recommend increasing the filter assembly by 1~2 sizes.

Step 1: Calculate ΔP coefficient for actual viscosity

Using Saybolt Universal Seconds (SUS)

$$\Delta P \text{ Coefficient} = \frac{\text{Actual Operating Viscosity}^1 \text{ (SUS)}}{150} \times \frac{\text{Actual Specific Gravity}}{0.86}$$

Using Centistokes (cSt)

$$\Delta P \text{ Coefficient} = \frac{\text{Actual Operating Viscosity}^1 \text{ (cSt)}}{32} \times \frac{\text{Actual Specific Gravity}}{0.86}$$

Step 2: Calculate actual clean filter assembly ΔP at both operating and cold start viscosity

$$\text{Actual Assembly Clean } \Delta P = \text{Flow Rate} \times \Delta P \text{ Coefficient (from Step 1)} \times \text{Assembly } \Delta P \text{ Factor (from sizing table)}$$

Filter Sizing¹

Filter assembly clean element ΔP after actual viscosity correction should not exceed 10% of filter assembly bypass setting. See above for filter assembly sizing guidelines. For applications with extreme cold start condition contact Hy-Pro for sizing recommendations.

ΔP Factors¹

Series	Length	Units	Media							
			1M	3M	6M	10M	16M	25M	**W	
PFH840	L15	psid/gpm	0.1613	0.1361	0.1055	0.0946	0.0926	0.0892	0.0160	
		bard/lpm	0.0029	0.0025	0.0019	0.0017	0.0017	0.0016	0.0003	
	L26	psid/gpm	0.1054	0.0889	0.0689	0.0618	0.0605	0.0582	0.0105	
		bard/lpm	0.0019	0.0016	0.0013	0.0011	0.0011	0.0011	0.0002	

¹Max flow rates and ΔP factors assume $\nu = 150$ SUS, 32 cSt. See filter assembly sizing guideline for viscosity conversion formula on page 22 for viscosity change.

PFH840 Specifications

Dimensions See Installation Drawings on page 237 for model specific dimensions.

Operating Temperature	Fluid Temperature	Ambient Temperature
	30°F to 225°F (0°C to 105°C)	-4°F to 140°F (-20C to 60C)

Operating Pressure

PFH840
5800 psi (400 bar)
min. 2 x 10⁶ pressure cycles
Nominal pressure according to DIN 24550

Flow Fatigue Rating

PFH840
9137 (630 bar)
min. 2 x 10⁴ pressure cycles
Quasi-static operating pressure

ΔP Indicator Trigger 73 psid (5 bard)

Element Collapse Rating	HP***N	HP***H	HP***C
	450 psid (31.0 bard) max	3000 psid (206.8 bard) max	250 psid (17.2 bard) max

Integral Bypass Setting

PFH840
87 psid (6.0 bard) – Integral element bypass

Materials of Construction	Head	Bowl with Drain Plug	Interior Coating	Exterior Coating
	Cast steel	DOM tubing	Phosphate	Industrial powder coating

Media Description	M	A	W
	G8 Dualglass, our latest generation of DFE rated, high performance glass media for all hydraulic & lubrication fluids. $\beta_{x_{[c]}} \geq 4000$	G8 Dualglass high performance media combined with water removal scrim. $\beta_{x_{[c]}} \geq 4000$	Stainless steel wire mesh media $\beta_{x_{[c]}} \geq 2$ ($\beta_x \geq 2$)

Replacement Elements [To determine replacement elements, use the selected codes from the following page below:](#)

Series Code	Filter Element Part Number	Example
840	HP840[Collapse Code] L [Length Code] – [Media Selection Code][Seal Code]	HP840NL15-25MB

When Special Option "N" selected for housing, add "-N" to end of filter element part number for compatible Nickel plated filter element. Example: HP840NL8-6MV-N

Fluid Compatibility Biodegradable and mineral based fluids. For high water based or specified synthetics consult factory.



PFH840 Part Number Builder



Connection **C32** 2" Code 62 flange (6000 psi)

Collapse Rating

C² 250 psid (17.2 bard) – Coreless element with integral bypass (includes post assembly for element support)
H 3000 psid (206.8 bard) – High collapse element with no housing bypass
N³ 450 psid (31.2 bard) – Core-in element with housing bypass

Length

15 15" (38 cm) nominal
26 26" (66 cm) nominal

Bypass

7⁴ 87 psid (6 bard) bypass
X⁵ No bypass

ΔP Indicator

DX Electrical switch only (DIN connection)
L Visual with electric switch (DIN connection) + LED indicator
V Visual
X No indicator (port plugged)

Media Selection

G8 Dualglass	G8 Dualglass + water removal	Stainless wire mesh
1M β _{3(c)} ≥ 4000	3A β _{5(c)} ≥ 4000	25W 25μ nominal
3M β _{5(c)} ≥ 4000	6A β _{7(c)} ≥ 4000	40W 40μ nominal
6M β _{7(c)} ≥ 4000	10A β _{12(c)} ≥ 4000	74W 74μ nominal
10M β _{12(c)} ≥ 4000	25A β _{22(c)} ≥ 4000	149W 149μ nominal
16M β _{17(c)} ≥ 4000		
25M β _{22(c)} ≥ 4000		

Seals

B Nitrile (Buna)
V⁷ Fluorocarbon
E-WS⁷ EPR seals + stainless steel support mesh

Maximum recommended flow rate based on velocity through port and internal flow path. Consult sizing guidelines or consult factory for sizing based on flow rate, viscosity, temperature, filter media selection. Available on PFH840 only.

PFH840 includes integral element bypass and does not include a bypass in the housing.

PFH840 bypass setting is 87 psid (6.0 bard).

⁴Only available when paired with "H" high collapse element.

⁷When selected, automatically adds nickel plating to filter element. For replacement elements, add "N" to end of filter element part number. Not available on PFH840 series.

⁷Not available with PFH840 series housings.

For all up to date option details and compatibilities, please reference our [Contamination Solutions Price List](#) or [contact customer service](#).



Filtration starts with the filter.

Lower ISO Codes: Lower Total Cost of Ownership Hy-Pro filter elements deliver lower operating ISO Codes so you know your fluids are always clean, meaning lower total cost of ownership and reducing element consumption, downtime, repairs, and efficiency losses.

DFE Rated Filter Elements DFE is Hy-Pro's proprietary testing process which extends ISO 16889 Multi Pass testing to include real world, dynamic conditions and ensures that our filter elements excel in your most demanding hydraulic and lube applications.

Upgrade Your Filtration Keeping fluids clean results in big reliability gains and upgrading to Hy-Pro filter elements is the first step to clean oil and improved efficiency.

Advanced Media Options DFE glass media maintaining efficiency to $\beta_{3[\mu]}$ > 4000, Dualglass + water removal media to remove free and emulsified water, stainless wire mesh for coarse filtration applications, and Dynafuzz stainless fiber media for EHC and aerospace applications.

Delivery in days, not weeks From a massive inventory of ready-to-ship filter elements to flexible manufacturing processes, Hy-Pro is equipped for incredibly fast response time to ensure you get your filter elements and protect your uptime.

More than just filtration Purchasing Hy-Pro filter elements means you not only get the best filters, you also get the unrivaled support, training, knowledge and expertise of the Hy-Pro team working shoulder-to-shoulder with you to eliminate fluid contamination.

Want to find out more? Get in touch.

hyprofiltration.com
info@hyprofiltration.com
+1 317 849 3535

© 2023 Hy-Pro Corporation. All rights reserved.



MKTLITFAS-PFH-051223-EM