



LFW

Wall Mounted Filter Assemblies

A compact, dedicated off-line contamination solution ideal for small reservoirs, gearboxes and diesel engine crankcase conditioning. Coming in at a whopping 0 ft² of floor space, the LFW is designed to get your filtration off the ground and positioned conveniently for you, whether you're polishing off that high viscosity gearbox oil or just want to add a little more protection for your critical components from heavy contaminants. And with Hy-Pro filter elements inside, the possibilities are endless for what you can do with the LFW.

Max Operating Pressure: 150 psi (10 bar)
Available options up to 250 psi (17.2 bar)



hyprofiltration.com/

Elements that go beyond industry standard.

DFE rated advanced media technologies provide the highest level of particulate capture and retention capabilities so your equipment operates unimpeded by contamination. With media options down to $\beta_{3, \mu} > 4000$ + water absorption and integral element bypass valves, you get the perfect element for your application, every time.



User friendly on a whole new scale.

With everything you need together in one tiny little package, LFW service and operation couldn't be easier. From the top loading housing to the sample ports, the LFW is built to match powerful filtration with your convenience. And with the easy-open swing bolt enclosure, worrying about lost parts during service becomes a thing of the past.

On board fuel filter upgrade.

New diesel engine fuel cleanliness requirements for high pressure injectors call for higher efficiency filters, rendering your existing on-board filters too small. The LFW element is sized just right and with available water absorbing media options, you'll get clean, dry fuel and the knowledge that your diesel engines are running more efficiently than ever.



Dedicated to your success.

The LFW provides dedicated in-line filtration to help you stay in control of total system cleanliness and prolong the life of your critical components. And with standard sample ports in their proper positions for best practice sampling, you'll be able to see just how good it can be running your equipment with clean oil.

AW oils, say goodbye to varnish.

LFW fitted with VTM media removes insoluble varnish and water while delivering incredibly low ISO Codes. Ideal for plastic injection molding and steel mill hydraulics with sensitive servo controls that fall victim to high temperature related insoluble varnish issues.

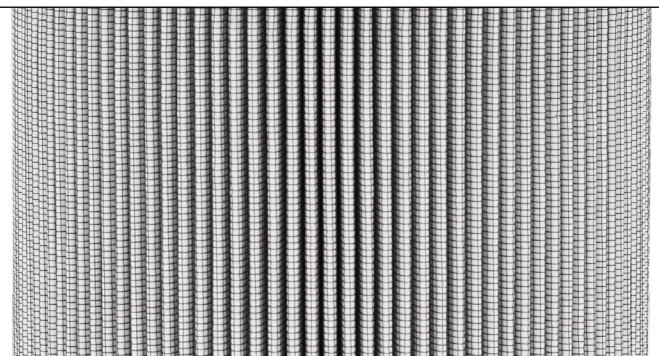

Small size, huge results.

LFW provides world class filtration in all the tight spaces where you need it most with a compact wall mount arrangement. Combine with a second LFW modular housing for multiple filtration passes and incredibly low ISO Codes, or to combine water and particulate removal technologies in series for the perfect comprehensive filtration system.

LFW Reference Guide

Air bleed valve

Top loading filter housing with secure swivel bolts

Mounting plate

True green to red ΔP gauge

Assembly ID tag

Vessel drain

System inlet

System outlet

Inlet sample port

Outlet sample port



LFM Installation Drawings

Front View

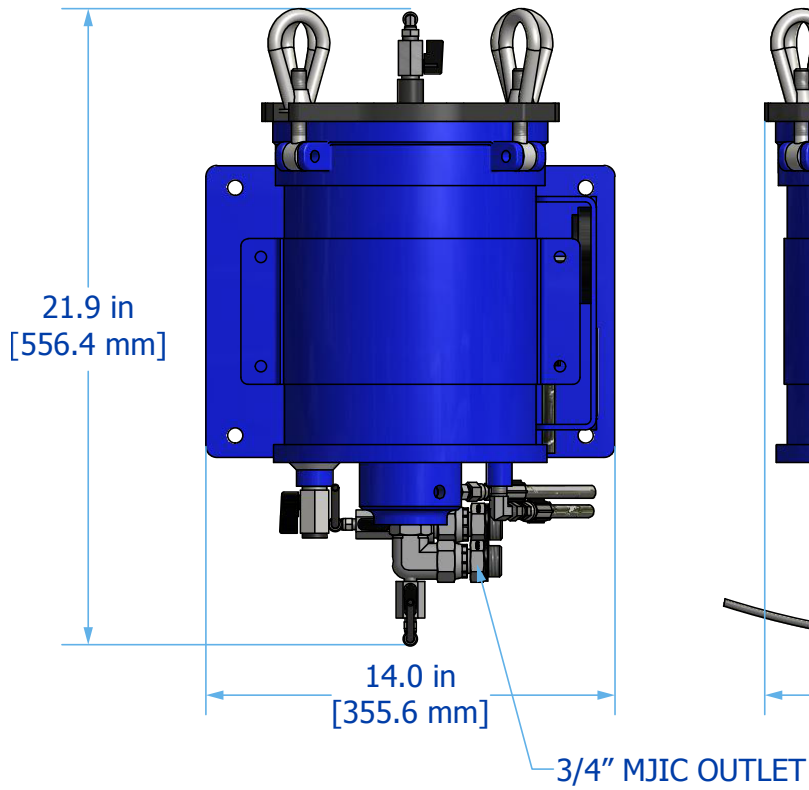

Side View

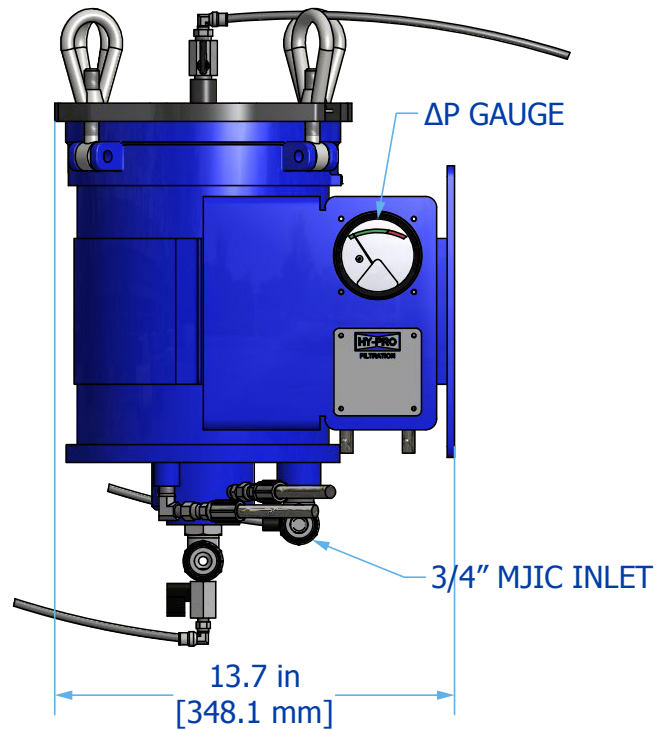

Mounting Pattern

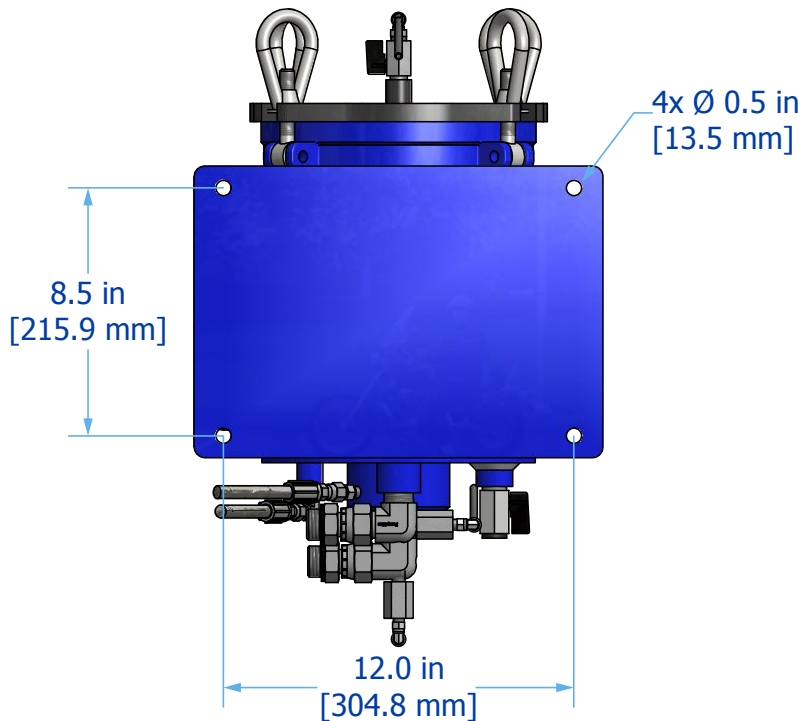

Filter Assembly Sizing

Filter Assembly Sizing Guidelines

Effective filter sizing requires consideration of flow rate, viscosity (operating and cold start), fluid type and degree of filtration. When properly sized, bypass during cold start can be avoided/minimized and optimum element efficiency and life achieved. The filter assembly differential pressure values provided for sizing differ for each media code, and assume 32 cSt (150 SUS) viscosity and 0.86 fluid specific gravity. Use the following steps to calculate clean element assembly pressure drop.

Calculate ΔP coefficient for actual viscosity

Using Saybolt Universal Seconds (SUS)

$$\Delta P \text{ Coefficient} = \frac{\text{Actual Operating Viscosity}^1 \text{ (SUS)}}{150} \times \frac{\text{Actual Specific Gravity}}{0.86}$$

Using Centistokes (cSt)

$$\Delta P \text{ Coefficient} = \frac{\text{Actual Operating Viscosity}^1 \text{ (cSt)}}{32} \times \frac{\text{Actual Specific Gravity}}{0.86}$$

Calculate actual clean filter assembly ΔP at both operating and cold start viscosity

$$\text{Actual Assembly Clean } \Delta P = \text{Flow Rate} \times \frac{\Delta P \text{ Coefficient (from calculation above)}}{\text{Assembly } \Delta P \text{ Factor (from sizing table)}}$$

Sizing recommendations to optimize performance and permit future flexibility

- To avoid or minimize bypass during cold start the actual assembly clean ΔP calculation should be repeated for start-up conditions if cold starts are frequent.
- Actual assembly clean ΔP should not exceed 10% of bypass ΔP gauge/indicator set point at normal operating viscosity.
- If suitable assembly size is approaching the upper limit of the recommended flow rate at the desired degree of filtration consider increasing the assembly to the next larger size if a finer degree of filtration might be preferred in the future. This practice allows the future flexibility to enhance fluid cleanliness without compromising clean ΔP or filter element life.
- Once a suitable filter assembly size is determined consider increasing the assembly to the next larger size to optimize filter element life and avoid bypass during cold start.
- When using water glycol or other specified synthetics we recommend increasing the filter assembly by 1~2 sizes.

LFW Specifications

Dimensions See Installation Drawings on page 187 for model specific dimensions.

Operating Pressure 150 psi (10 bar) maximum standard.

Operating Temperature	Fluid Temperature	Ambient Temperature
	30°F to 225°F (0°C to 105°C)	-4°F to 140°F (-20C to 60C)

Materials of Construction	Vessel	Element Bypass Valve
	Carbon steel with industrial coating	Nickel plated steel

Media Description	M	A	VTM	W
	G8 Dualglass, our latest generation of DFE rated, high performance glass media for all hydraulic & lubrication fluids. $\beta_{x_{[C]}} \geq 4000$	G8 Dualglass high performance media combined with water removal scrim. $\beta_{x_{[C]}} \geq 4000$	$\beta_{3_{[C]}} \geq 4000$ particulate, insoluble oxidation by-product and water removal media	Stainless steel wire mesh media $\beta_{x_{[C]}} \geq 2$ ($\beta_x \geq 2$)

Replacement Elements To determine replacement elements, use corresponding codes from your assembly part number:

Element Type Code	Filter Element Part Number	Example
6	HP106L10 - [Media Selection Code] [Seal Code]	HP106L10-10AB
7	HP107L10 - [Media Selection Code] [Seal Code]	HP107L10-3MV

Fluid Compatibility Petroleum and mineral based fluids, #2 diesel fuels (standard). For specified synthetics contact factory for compatibility with fluorocarbon seal option. For phosphate ester (P9) or skydrol fluid (S9) compatibility select fluid compatibility from special options.

Filter Sizing¹ Filter assembly clean element ΔP after actual viscosity correction should not exceed 10% of filter assembly bypass setting. See previous page for filter assembly sizing guidelines. For applications with extreme cold start condition contact Hy-Pro for sizing recommendations.

ΔP Factors ¹	Units	Media							
		VTM	1M	3M	6L	10M	16M	25M	**W
	psid/gpm	0.1700	0.1670	0.0980	0.0600	0.0390	0.0250	0.0200	0.0160
	bard/lpm	0.0031	0.0030	0.0018	0.0011	0.0007	0.0005	0.0004	0.0003

¹Max flow rates and ΔP factors assume $u = 150$ SUS, 32 cSt. See filter assembly sizing guideline for viscosity conversion formula on page 22 for viscosity change.



LFW Part Number Builder

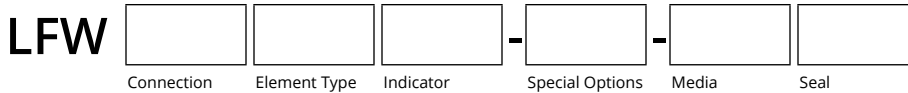

Connection	Port Option	Max Flow Rate
G12	¾" G thread (BSPP)	25 gpm (95 lpm) ¹
J12	¾" male JIC with 37° flare	25 gpm (95 lpm) ¹
N12	¾" FNPT	25 gpm (95 lpm) ¹

Element Type	
6	HP106 coreless element, 25 psid (1.7 bard) integral element bypass
7	HP107 coreless element, 50 psid (3.4 bard) integral element bypass

ΔP Indicator	
D	22 psid visual gauge + electric switch
E	22 psid visual gauge
F	45 psid visual gauge + electric switch
G	45 psid visual gauge
P	2 pressure gages (industrial liquid filled)

Special Options	
F	Filter element ΔP gauge with tattle tale follower needle
P9²	Phosphate ester fluid compatibility modification
S2	51" (130 cm) Mounting stand – ships fully assembled
S9³	Skydrol fluid compatibility modification
W	Automatic air bleed valve

Media Selection	G8 Dualglass	G8 Dualglass + water removal
0.5M	$\beta_{0.9, [C]} \geq 4000$	3A $\beta_{5, [C]} \geq 4000$
1M	$\beta_{3, [C]} \geq 4000$	6A $\beta_{7, [C]} \geq 4000$
3M	$\beta_{5, [C]} \geq 4000$	10A $\beta_{12, [C]} \geq 4000$
6L	$\beta_{7, [C]} \geq 4000$	25A $\beta_{22, [C]} \geq 4000$
10M	$\beta_{12, [C]} \geq 4000$	
16M	$\beta_{17, [C]} \geq 4000$	
25M	$\beta_{22, [C]} \geq 4000$	

VTM	Stainless wire mesh
VTM710⁴ $\beta_{3, [C]} \geq 4000$ particulate, insoluble oxidation by-product and water removal media	25W 25μ nominal
	40W 40μ nominal
	74W 74μ nominal
	149W 149μ nominal

Seals	
B	Nitrile (Buna)
V	Fluorocarbon
E-WS	EPR seals + stainless steel support mesh

¹Maximum recommended flow rate based on velocity through port and internal flow path. Consult sizing guidelines or consult factory for sizing based on flow rate, viscosity, temperature, filter media selection.

²When selected, must be paired with Seal option "V." Contact factory for more information or assistance in fluid compatibility.

³When selected, must be paired with Seal option "E-WS." Contact factory for more information or assistance in fluid compatibility.

⁴Only available on HP107 series elements. Max recommended flow rate 4 gpm (15 lpm) for HP107L10-VTM710* elements.

For all up to date option details and compatibilities, please reference our [Contamination Solutions Price List](#) or contact customer service.



Filtration starts with the filter.

Lower ISO Codes: Lower Total Cost of Ownership Hy-Pro filter elements deliver lower operating ISO Codes so you know your fluids are always clean, meaning lower total cost of ownership and reducing element consumption, downtime, repairs, and efficiency losses.

DFE Rated Filter Elements DFE is Hy-Pro's proprietary testing process which extends ISO 16889 Multi Pass testing to include real world, dynamic conditions and ensures that our filter elements excel in your most demanding hydraulic and lube applications.

Upgrade Your Filtration Keeping fluids clean results in big reliability gains and upgrading to Hy-Pro filter elements is the first step to clean oil and improved efficiency.

Advanced Media Options DFE glass media maintaining efficiency to $\beta_{3[\mu]} > 4000$, Dualglass + water removal media to remove free and emulsified water, stainless wire mesh for coarse filtration applications, and Dynafuzz stainless fiber media for EHC and aerospace applications.

Delivery in days, not weeks From a massive inventory of ready-to-ship filter elements to flexible manufacturing processes, Hy-Pro is equipped for incredibly fast response time to ensure you get your filter elements and protect your uptime.

More than just filtration Purchasing Hy-Pro filter elements means you not only get the best filters, you also get the unrivaled support, training, knowledge and expertise of the Hy-Pro team working shoulder-to-shoulder with you to eliminate fluid contamination.



Want to find out more? Get in touch.

hyprofiltration.com
info@hyprofiltration.com
+1 317 849 3535

© 2023 Hy-Pro Corporation. All rights reserved.



MKTLITFAS-LFW-051223-EM