

HY-PRO

Fluid Contamination Solutions

GENERAL BROCHURE

© 2023 Hy-Pro Corporation. All rights reserved.





Our Story



At Hy-Pro, we are advancing hydraulic, lubrication, and fuel filtration for a cleaner world. We strive to make our customers as efficient as possible and help achieve their sustainability objectives. We do this by improving the reliability of hydraulic and lube oil assets with industry-leading filter elements and contamination solutions equipment. We stop equipment failures and downtime, drive more efficient production and eliminate the waste and environmental impact caused by contamination-related premature fluid disposal. It is our goal to eliminate industrial fluid contamination and all difficulties related to it.

Innovation drives the growth of Hy-Pro to solve the industry's toughest contamination challenges with world-class filtration and strategies to combat fluid contamination. Our state-of-the-art manufacturing facilities are home to vertically integrated and flexible build processes that allow us to leverage Hy-Pro and Donaldson manufacturing, streamlined manufacturing, and create tailored solutions to our customers' challenges. We thrive on continually improving and identifying new ways to enhance customer experience. We develop cutting-edge medias and best-in-class products supported by technical experts, oil sampling, on-line conditioning monitoring, sample results analysis and interpretation, customer service that works hard for you, and the world's most comprehensive critical filter element interchange; Hy-Pro is the most complete and effective fluid contamination solutions provider.

Our value-add distributor and partners work shoulder to shoulder with our Hy-Pro Field Tech Reps to optimize plant efficiency, troubleshoot, teach, and drive bottom-line profitability. We deliver fast, reliable service on a local level to build mutually beneficial relationships to make our customers better. Those relationships, along with our nonstop desire for progress, allow us to improve the lives of our customers across the world.

Aaron Hoeg
General Manager

What we're about

Advanced Media Technology

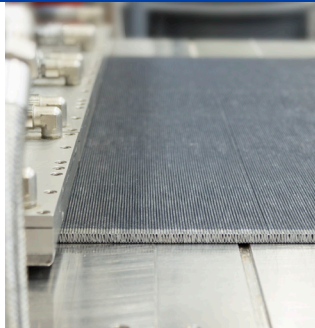

Innovative media development and DFE rated filter elements are the core of Hy-Pro's products, delivering lower operating ISO Codes for reliable plant operation. Optimized vacuum dehydration, coalesce and nitrogen membrane water removal technologies eliminate critical system water related failures. Ion Charge Bonding (ICB) treatment of specified lube and hydraulic oils addresses fluid contamination on a molecular level to prevent servo valve failures and extend fluid life. Dedicated smart off-line filtration systems condition extremely high viscosity oils that were previously considered not filterable. And that's just scratching the surface of what Hy-Pro can do.

The Highest Quality



Engineered, manufactured and tested in our state of the art facilities across the US, our contamination solutions are built to be rugged, dependable, and easy to use. From the highest quality materials and components, we deliver the best filtration equipment anywhere in the world. The same quality goes into Hy-Pro filter elements, eliminating any contamination challenge imaginable to provide our customers with the incredible results and peace of mind they deserve.

Unmatched Expertise



Work with Hy-Pro and you're working shoulder-to-shoulder with the industry experts to implement contamination control and prevention in all things industrial fluid. But it doesn't stop there. From customized strategies and long term solutions to on-site service, support and training, our expert Field Technical Reps are involved from before implementation begins to long after the life of the filter element to ensure our customers are provided the best solutions for their specific contamination problems.

Flexible Design & Manufacturing

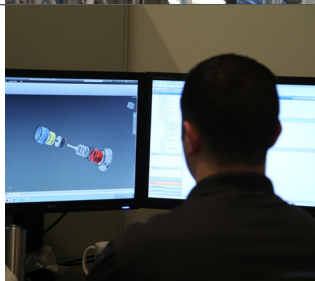

Whether you're selecting the perfect options from our standard product lines or need a completely custom, one of a kind solution, we listen to your needs and collaborate with you to deliver a specific contamination solution to fit your exact application.

Rapid Response



The flexibility in our manufacturing processes along with our extensive inventory of ready-to-ship filter elements allow us to respond to any situation with incredible speed. For standard delivery, you'll receive your elements in days, not weeks. And in some cases like the event of any emergency or upset situation, we're even able to deliver your exact filter element in hours to maximize your uptime and keep your plant running efficiently.

Eliminate Waste & Protect the Environment



Through contamination control and molecular treatment, Hy-Pro extends the useful life of critical hydraulic and lube oils to improve reliability and bottom line profitability. Preventing premature fluid replacement reduces environmental impact, which is a responsibility that falls on everyone. With our products and efforts in fluid management, we continue to bring conservation of natural resources and reduction of industrial waste to the forefront.

Dynamic Filter Efficiency

DFE MATCHES FILTER TESTING WITH REAL-LIFE CONDITIONS

All hydraulic and lube systems have a critical contamination tolerance level that is often defined by, but not limited to, the most sensitive system component such as servo valves or high speed journal bearings. Defining the ISO fluid cleanliness code upper limit is a function of component sensitivity, safety, system criticality and ultimately getting the most out of hydraulic and lube assets.

Filters remove the particulate contamination that enters a system or is generated by the system as it operates. All filters are subjected to some form of system dynamics: hydraulic filters encounter frequent and rapid changes in flow rate when valves shift, cylinders unload and pump output changes; lube filters experience dynamic conditions during start up and shut down. Filters validated only to current ISO testing standards don't perform as expected when subjected to the demands of real world dynamic operating systems.

A filter is not a black hole. Two key characteristics of filter performance are capture efficiency and retention efficiency. Capture efficiency can be thought of simply as how effectively a filter captures particles while retention efficiency is a measure of how effectively that filter retains the particles it has captured. A filter is not a black hole, and its performance must not be based solely on how efficiently it captures particles. If not properly designed and applied, a filter can become one of the most damaging sources of contamination in a system if it releases previously captured particles when challenged with dynamic conditions.

The Dynamic Filter Efficiency Test (DFE) is the evolution of standard hydraulic and lube filter performance testing. DFE goes further than current industry standards to quantify capture and retention efficiency in real time by inducing dynamic duty cycles, measuring real-time performance during dynamic changes and the filters ability to retain particles. DFE testing is the method for predicting worst case fluid cleanliness along with average fluid cleanliness. The DFE test method was pioneered in 1998 during a joint effort between Scientific Services Inc (SSI) and Hy-Pro Filtration.



Dynamic Filter Efficiency

Current Filter Performance Testing Methods

To understand the need for DFE it is important to understand how filters are currently tested and validated. Manufacturers use the industry standard ISO16889 multi-pass test to rate filter efficiency and dirt holding capacity of filter elements under ideal lab conditions.

Figure 1 depicts the test circuit where hydraulic fluid is circulated at a constant flow rate in a closed loop system with on-line particle counters before and after the test filter. Contaminated fluid is added to the system at a constant rate. Small amounts of fluid are removed before and after the filter for particle counting to calculate the filter efficiency (capture). The capture efficiency is expressed as the Filtration Ratio (Beta) which is the relationship between the number of particles greater than and equal to a specified size ($X_{\mu_{[c]}}$) counted before and after the filter. In real world terms this test is the equivalent of testing a filter in an off-line kidney loop rather than replicating an actual hydraulic or lube system. It's basically a filter cart test.

Figure 1: ISO16889 Multi-Pass Test

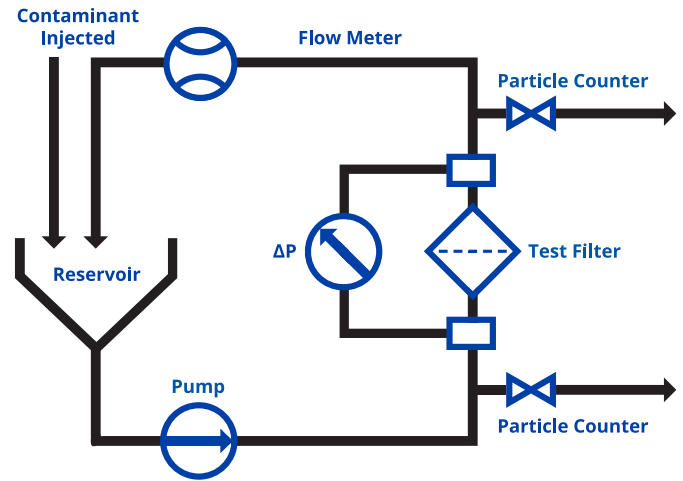

Filtration Ratio (Beta) per ISO16889:

$$\beta_{X_{[c]}} = \frac{\text{quantity particles} \geq X_{\mu_{[c]}} \text{ upstream of filter}}{\text{quantity particles} \geq X_{\mu_{[c]}} \text{ downstream of filter}}$$

Example: $\beta_{7_{[c]}} = 600/4 = 150$
Filtration Ratio (Beta): $\beta_{7_{[c]}} = 150$

In the example, 600 particles greater than or equal to $7\mu_{[c]}$ were counted upstream of the filter and 4 were counted downstream. This Filtration Ratio is expressed as "Beta $7_{[c]} = 150$ ". The $_{[c]}$ is referred to as "sub c". The sub c is used to differentiate between multi-pass tests run per the current ISO16889 multi-pass test with new particle counter calibration per ISO11171 from ISO4572. Filtration Ratio expressed or written without the "sub c" refers to the antiquated ISO4572 multi-pass test superseded by ISO16889. The efficiency may also be expressed as a percentage by converting the Filtration Ratio:

$$\text{Efficiency of } \beta_{X_{[c]}} = \frac{(\beta - 1)}{\beta} \times 100$$

Example: **Efficiency % of $\beta_{7_{[c]}} = 150$** $= (150 - 1) / 150 \times 100$
Efficiency %: **99.33%**

Using our Beta Ratio found in the first example, we can calculate that the test filter is 99.33% efficient at capturing particles $7\mu_{[c]}$ and larger.

DFE Filter Element Technology

Quantifying Contaminant Capture and Retention

Filters for critical hydraulic, lube and fuel systems are specifically designed for high efficiency particle capture. However, a filter is not a black hole, capturing and retaining particles in a real-world dynamic environment is far more challenging. Hy-Pro pioneered the DFE (Dynamic Filter Efficiency) multipass test to optimize performance under real-world conditions. This methodology drives the development of proprietary media layers, media support structure, and filter construction. The results are higher efficiency particle capture and retention and cleaner fluids when Hy-Pro upgrade elements are in service.

Hy-Pro uses DFE and the ISO/CD23369 Cyclic Flow Multi-Pass Test to benchmark performance between its filters and those of its competitors. The Cyclic Flow Multi-Pass protocol ISO/CD23369 moves the industry standard one step closer to real-world conditions by incorporating cyclic flow with rapid flow transitions (between 100-200 msec) as shown in Figure 2.

Figure 2: ISO23369 Flow Cycle

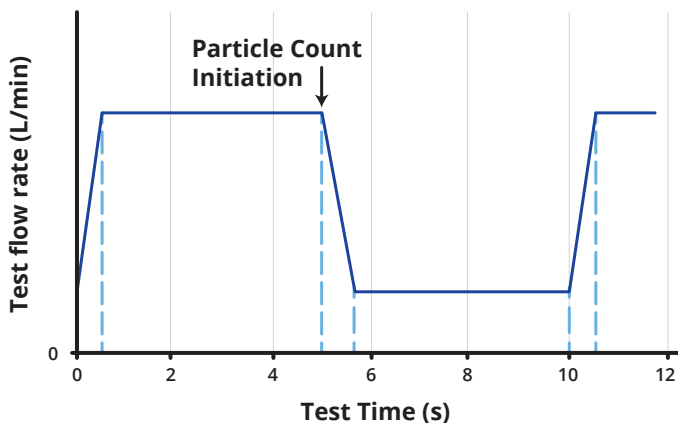

Table 1 illustrates this differentiation during dynamic conditions. Hy-Pro filters and a competitor's filters (Filter X) of similar rating were tested using ISO16889 and ISO23369. The average Beta ratios are listed and plotted vs particle size in Figure 3. Under static ISO16889 (dashed lines) both filters easily exceeded a Beta ratio of $B7_{[c]} > 2000$ (Hy-Pro filter averaged $\beta 6.2\mu\text{m}=2000$, Filter X averaged a higher level of performance, $\beta 6.0\mu\text{m}=2000$). In beta ratios the lower the BX number the better the efficiency.

Table 1: Test Conditions and Results

ISO/CD23369 Test Conditions		
Flow Rates	114 lpm:28.5 lpm (30 gpm:7.5 gpm)	
ISO16889 Test Results		
	Hy-Pro	Filter X
$\beta \geq 1000$	6.2 μm	6.0 μm
ISO/CD23369 Test Results		
	Hy-Pro	Filter X
$\beta \geq 1000$	7.2 μm	10.6 μm
$\beta \geq 2000$	8.1 μm	12.9 μm
$\beta \geq 4000$	9.2 μm	17.7 μm

But that is where the similarity ends. The Hy-Pro DFE rated filter element shifted from 6.2 μm during static testing to 8.1 μm during dynamic conditions – a shift of only 1.9 μm . Filter X shifted from 6.0 μm to 12.9 μm , from static to dynamic conditions – a 6.9 μm drop, 6 times greater efficiency loss at $Bx \geq 2000$ than Hy-Pro. And these differences dramatically increased at higher Beta ratios with Filter X falling to 17.7 μm at $\beta \geq 4000$.

Hy-Pro DFE rated filter elements are optimized to deliver and maintain the lowest real world, in-service ISO fluid cleanliness codes even in industry's toughest systems. This is what separates Hy-Pro from the rest and how we improve your reliability, efficiency and keep your fluids cleaner and always in spec.

Figure 3: ISO16889 & ISO23369 Avg Beta vs Particle Size

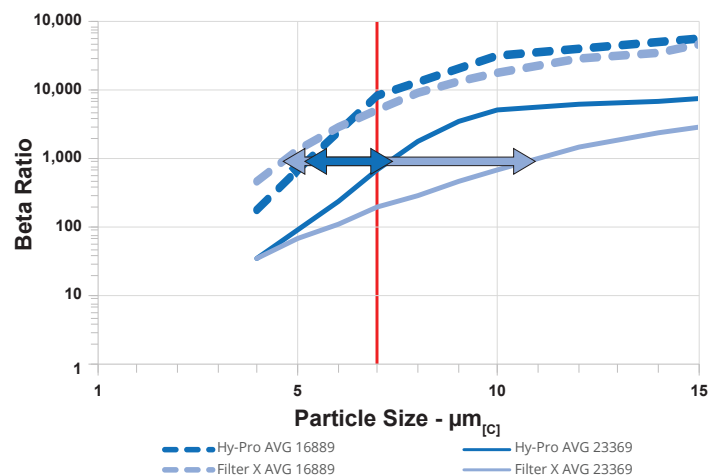

Hy-Pro's Competitive Advantage

DFE Multi-Pass: Cold Start Contamination Retention

Hy-Pro utilizes DFE to bridge the gap between lab and real world filter performance for hydraulic, lube and fuel systems. The DFE restart test challenges a filter's ability to retain the contaminants it has captured in a worst-case scenario, once the filter is near the end of its life. Once the filter is heavily loaded the DFE test main flow and particle injection systems are stopped for a short dwell time, then full flow is restarted without injection to measure what comes out of the filter. After restart the DFE cycle is repeated several times all while the downstream particle counts are monitored in real time. The developmental value of the DFE test is the continuous, real time particle counts that occur concurrently every 5 seconds measuring actual retention efficiency during flow changes and restart (Figure 4). This is the advantage of DFE over ISO/CD23369 Cyclic Flow Multi-Pass test, where several high frequency flow changes are normalized over 30-60 second particle counts. ISO/CD23369 would miss the short-term particle events captured by the DFE test.

Figure 4: ISO/CD23369 vs DFE Multi-Pass

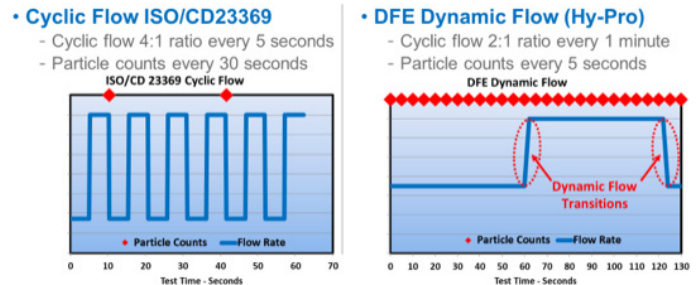

Restarts in hydraulic, lubrication and fuel systems are one of the toughest conditions for a filter and for this reason Hy-Pro includes it in the DFE test. A filter that doesn't properly retain is a dangerous source of concentrated contamination in front of critical components and bearings. Figures 5 and 6 depict the particles released during restart for Filter X and Hy-Pro. The DFE rated Hy-Pro element has much higher retention efficiency than filters designed and validated only to ISO16889 multi-pass or ISO23369. In the real world this means that Hy-Pro DFE rated elements provide lower ISO codes (consistently cleaner oil) and better protection of your critical equipment and uptime.

Figure 5: Filter X DFE Restart Test

Released 1810 particles/ml $\geq 4\mu\text{m}_{[c]}$

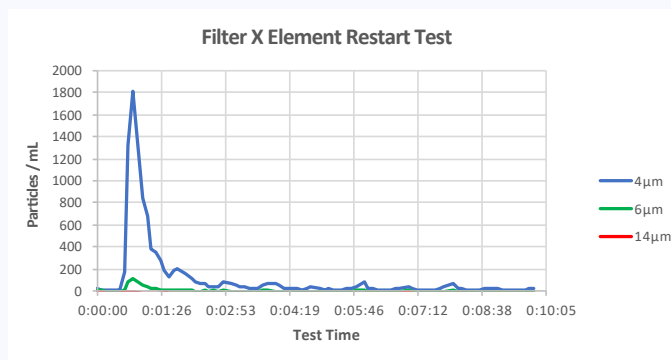
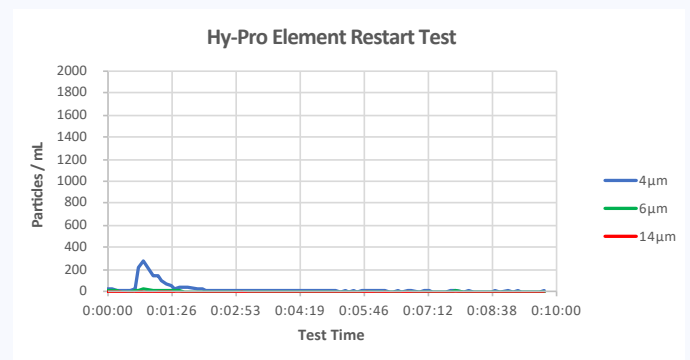

Figure 6: Hy-Pro DFE Restart Test

Released 283 particles/ml $\geq 4\mu\text{m}_{[c]}$



Downstream Particle Counts / mL During Restart Test

	$\geq 4\mu\text{m}_{[c]}$	$\geq 6\mu\text{m}_{[c]}$	$\geq 14\mu\text{m}_{[c]}$	ISO Code per ISO: 4406:1999	ADHC
Hy-Pro Element	283	29	1.8	15/12/8	54.17g
Element X	1,810	117	1.2	18/14/7	53.27g

High Performance Filter Elements

Lowering Costs & Increasing Efficiency

Our mission is to make our customers as efficient as possible, and we achieve that with the highest quality filtration products and total system cleanliness strategies to maximize uptime, productivity and prevent costly fluid contamination related failures. Been there. Done that. Going to do it again tomorrow. But that's not the only way we make our customers efficient. Extending the useful life of in-service fluids pays big dividends

in reliability, saves money on premature fluid replacement costs, and reduces the environmental impact of industry by reducing the amount of fluids used and discarded. Enhancing reliability, saving money, and protecting the environment are not only good business, they're our responsibility. To help reduce oil usage, let's first understand why fluids are condemned and prematurely replaced.



NSD

Non-Spark Discharge Filter Elements

Hy-Pro NSD element and media technology is optimized to prevent spark discharge and minimize potential energy in bearing lubrication and hydraulic control systems.

NSD elements prevent oil degradation caused by thermal events associated with element spark discharge to extend fluid life and prevent anti-oxidant additive depletion.

Water Removal

G8 Dualglass Media with Water Removal

Media code "A" specifies G8 Dualglass media co-pleated with water removal scrim to produce a filter that can remove water while maintaining $\beta_{x_{10}}=4000$ efficiency down to $3\mu_{10}$. Available for all Spin-On and cartridge style filter elements.



Coreless Filter Elements

Glass Fiber Media

Reduce rising disposal costs and minimize environmental impact by using coreless filter elements. A permanent inner liner is used in the housing instead of being replaced with every new element.

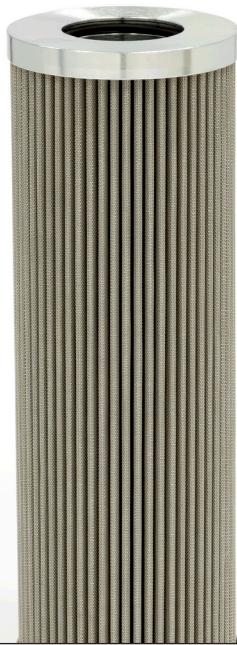
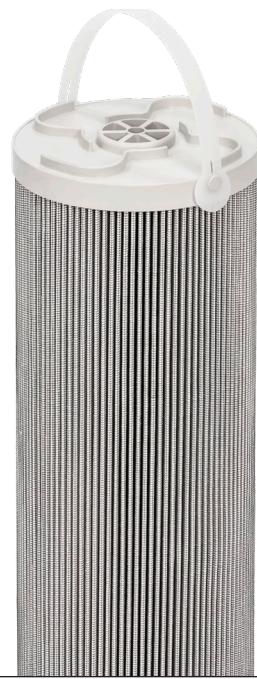

Dynafuzz

Stainless Fiber Media

Dynafuzz is ideal for long term exposure to aggressive fluids such as phosphate ester, Skydrol, Deionized water, and high temperature applications where traditional glass media binders can degrade leading to media migration. Popular media option in power generation with fire resistant fluids.

Lube Design

Low ΔP Optimized Glass Filter Media

A modified DFE rated glass media option for high flow lube systems with low ΔP alarm (1 bar, ~15 psid). Also ideal for undersized hydraulic filter assemblies or upgrading from wire mesh to high efficiency glass media.



Filter Assemblies

In-Tank Assemblies

TFRB

In-Tank Return Line Filter Assemblies

Hy-Pro TFRB in-tank filter assemblies are ideal for mobile and industrial power unit hydraulic applications where the breather integrated into the filter head can save space to yield a compact solution.

Max Operating Pressure: 150 psi (10.3 bar)



TFR

In-Tank Filter Assemblies

Hy-Pro TFR in-tank filter assemblies are ideal for particulate contamination removal in hydraulic power unit return line and mobile hydraulic OEM installations.

Max Operating Pressure: 150 psi (10 bar)



TF4

In-Tank Filter Assemblies

Ideal for installation on the return line to remove contaminant ingested or generated by the system.

Max Operating Pressure: 150 psi (10 bar)



TFR1

In-Tank Return Line Filter Assemblies

Hy-Pro TFR1 in-tank filter assemblies are ideal for particulate contamination removal in high velocity hydraulic power unit return line and compact mobile hydraulic OEM installations.

Max Operating Pressure: 150 psi (10 bar)

Filter Assemblies

Low Pressure Assemblies

LF(M)

High Viscosity Filter Assemblies

Low pressure filter assemblies optimized for high flow hydraulic, high viscosity lube and heavily contaminated fuel applications.

Max Operating Pressure: 150 psi (10 bar)

Available options up to 1000 psi (68.9 bar)



LFW

Wall Mounted Filter Assemblies

A compact, dedicated off-line contamination solution ideal for small reservoirs, gearboxes and diesel engine crankcase conditioning. Coming in at a whopping 0 ft² of floor space, the LFW is designed to get your filtration off the ground and positioned conveniently for you, whether you're polishing off that high viscosity gearbox oil or just want to add a little more protection for your critical components from heavy contaminants. And with Hy-Pro filter elements inside, the possibilities are endless for what you can do with the LFW.

Max Operating Pressure: 150 psi (10 bar)

Available options up to 250 psi (17.2 bar)

F8

Low Pressure Filter High Flow Filter Assembly

Ideal for high viscosity lubricating fluids, high flow hydraulic, and heavily contaminated fuel applications. Drop-in mounting interchange for common pulp and paper industry 8300/8310/8314 filter assemblies.

Max Operating Pressure: 500 psi (34.5 bar)



S75-76

Low Pressure Spin-On Filter Assemblies

Hy-Pro low pressure S series filters are designed for installation on the return line to remove contaminant ingested or generated by the system. Functions include off-line filtration (kidney loop or filter cart) and some suction applications.

Ideal for automotive manufacturing and assembly machine tools, mobile applications such as waste haulers and transit, filter carts and filter panels, and power unit return line/suction.

Max Operating Pressure: 200 psi (13.8 bar)



Filter Assemblies

Medium Pressure Assemblies

MF 90/110

Medium Pressure Filter Assemblies

Hy-Pro's MF90 and MF110 medium pressure filters are designed to protect sensitive components in hydraulic and transmission circuits. Install the series upstream of specific components or directly after the pressure pump in mid-flow systems to minimize risk of failure and costly system downtime.

Ideal for use as a charge pump discharge filter or a pilot filter, and to protect components that are sensitive to particulate contamination and require clean pressurized fluid for reliable operation.

Max Operating Pressure: 580 psi (40 bar)



MF3

Medium Pressure Filter Assemblies

Ideal for mobile equipment return line applications as an alternative to spin-ons, on-board fuel and dispensing and hydrostatic charge circuits.

Max Operating Pressure: 1,200 psi (83 bar)



Filter Assemblies

High Pressure Assemblies

PF2

High Pressure In-line Filter Assembly

Ideal for a variety of applications including mobile applications, paper and saw mills, power generation, general industrial machine tools, and automotive manufacturing. With HF2 compatible port-to-port dimension, mounting pattern, and element design to meet the automotive manufacturing standard.

Max Operating Pressure: 4000 psi (275 bar)



PF4

High Pressure Base Mounted Filter Assemblies

Hy-Pro PF4 pressure filters are designed for protecting sensitive components in hydraulic circuits. Install the series upstream of specific components or directly after the pressure pump to minimize risk of failure and costly system downtime.

Ideal for components that are sensitive to particulate contamination, such as the servo valve, and require clean pressurized fluid for reliable operation.

Max Operating Pressure: 6,000 psi (379 bar)



PFH

High Pressure In-Line Filter Assemblies

Hy-Pro's PFH14, PFH55, and PFH167 pressure filters are designed to protect sensitive components in hydraulic circuits. Install the series upstream of specific components or directly after the pressure pump in smaller systems to minimize risk of failure and costly system downtime.

Ideal for use as a power unit pump discharge filter or a pilot filter, and to protect components that are sensitive to particulate contamination and require clean pressurized fluid for reliable operation, such as servo valves.

Max Operating Pressure: 6090 psi (420 bar)



PFH62

High Pressure In-Line Filter Assemblies

Hy-Pro's PFH62 pressure filters are designed to protect sensitive components in hydraulic circuits. Install the series upstream of specific components or directly after the pressure pump to minimize risk of failure and costly system downtime.

Ideal for use as a power unit pump discharge filter and to protect components that are sensitive to particulate contamination and require clean pressurized fluid for reliable operation, such as servo valves.

Max Operating Pressure: 6,600 psi (455 bar)



PFH92

High Pressure In-Line Filter Assemblies

Hy-Pro's PFH92 pressure filters are designed to protect sensitive components in hydraulic circuits. Install the series upstream of specific components or directly after the pressure pump to minimize risk of system failure and costly downtime.

Ideal for use in all high pressure and high flow hydraulic applications.

Max Operating Pressure: 6,000 psi (414 bar)



PFH840

High Pressure In-line Filter Assemblies

Hy-Pro's PFH pressure filters are designed to protect sensitive components in hydraulic circuits. Install the series upstream of specific components or directly after the pressure pump in smaller systems to minimize risk of failure and costly system downtime.

Ideal for use on a power unit pump discharge filter or pilot filter directly in front of valves and actuators.

Max Operating Pressure: 9137 psi (630 bar)



PFHB

High Pressure Full Flow Bi-Directional Filter Assemblies

Hy-Pro's PFHB high pressure filter assemblies are designed for applications where flow direction changes and fluid must be filtered with full flow in both directions. Protect both components and clean fluid that typically does not return to the reservoir.

Ideal for steel mills, board plants, scrap yards, and concrete mixers.

Max Operating Pressure: 7250 psi (500 bar)

Filter Assemblies

Duplex Filter Assemblies

DFN

Low Pressure Duplex Filter Assembly

Designed to maintain continuous filtration, even throughout element servicing, the DFN series filter assemblies provide a compact and user-friendly 4-way, 2 position housing completely sealed from the atmosphere. Remove particulate and water from a variety of fluids including hydrogen seal, oil, turbine lube oil, bearing lube oil, and FD-ID-PA fan lube.

Ideal for systems where filters must be serviced without system interruption such as hydraulic, gearbox, wind turbine, boiler feed pump, mechanical/electro hydraulic control, and servo systems.

Max Operating Pressure: 888 psi (61.2 bar)



DFH

High Pressure Duplex Filter Assembly

The DFH series is designed to remove particulate and water from a variety of fluids including hydrogen seal oil, turbine lube oil, bearing lube oil, and FD-ID-PA fan lube. Applicable for wind turbine, boiler feed pump, mechanical/electro hydraulic control, and fuel handling systems.

Ideal for systems where filters must be serviced while continuous operation is not interrupted such as hydraulic, gearbox, and servo systems.

Max Operating Pressure: 3600 psi (248 bar)



DLF(M)

Low Pressure High Flow Duplex Filter Assembly

Designed to maintain continuous filtration, even throughout element servicing, the DLF series filter assemblies provide two high efficiency, high capacity filter housings coupled by a user-friendly 6-way, 3 position valve that completely seals the system from the atmosphere. Use the DLF(M) to remove particulate and water from a variety of fluids and maximize your uptime.

Ideal for systems where filters must be serviced without system interruption such as hydraulic, gearbox, pulp and paper, rolling mill oil, bulk oil handling, and high flow return-line filtration.

Max Operating Pressure: 150 psi (10 bar)

Available options up to 450 psi (31 bar)



Fluid Conditioning Equipment

Off-line Filter System

FPL

Dedicated Off-line Filter Panel

A dedicated contamination solution for bulk oil handling, fluid transfer and reservoir or gearbox conditioning.

Enhance cleanliness by adding the FPL to an existing hydraulic system and extend the life of in-line filters.



CFU

Compact Filter Unit

Bigger isn't always better. The Compact Filter Unit provides you with the best filtration at a size you can take anywhere. Tried and true, the CFU is the ultimate filtration system in power and mobility. And with easy to change cartridge style MF90s, you can rest easy knowing your filtration will always exceed your expectations.

COF

Compact Offline Filter

Our smallest unit yet, the Compact Offline Filter is able to fit where no other filtration equipment can. Ideal for smaller systems, or where a larger offline system wouldn't fit, can be permanently installed or portable.

Typical applications include gear boxes, plastic injection molding machines, and vacuum pumps, to name a few. Choose between a variety of motors, wands, hoses, and portable cart options. Paired with our unique VTM elements, this unit can remove particulate, water, and varnish all with one filter.



FC

Filter Cart

A fully self-contained mobile solution for bulk oil handling, fluid transfer and reservoir or gearbox conditioning.

Ideal for lower viscosity hydraulic oil, lube oil and diesel fuel.



FSL

High Viscosity Filtration Systems

A dedicated contamination solution for bulk oil handling and fluid transfer. Designed to excel in filtering particulate from heavily contaminated oil, the FSL keeps gearbox lubricant clean and equipment running efficiently.

Ideal for high viscosity gearbox or lube applications and highly contaminated fuel applications.

FSLD

High Viscosity Dual Filter Skids

A dedicated contamination solution for off-line conditioning and bulk oil handling. Dual housings allow flexibility in using staged element ratings to achieve remarkably clean fluids and hit target ISO Codes in fewer passes, all while extending filter element and oil life.

Ideal for conditioning reclaimed fluids or fluids with high dirt load.



FSW

Wall Mounted Filtration Systems

A compact, dedicated off-line contamination solution ideal for small reservoirs, gearboxes and diesel engine crankcase conditioning. Element media options for every application including particulate removal, water absorption, varnish and acid removal.

Compact and compatible, the FSW is the perfect off-line filtration system for removing contamination from your systems and making sure they remain in peak operating condition.



FCL

High Viscosity Filter Cart

A self contained solution for high viscosity bulk oil handling, fluid transfer and reservoir or gearbox conditioning.

Ideal for higher viscosity lube oil and highly contaminated fuel and hydraulic oil.

HS

Heater Skids

Designed to achieve target ISO Codes and safely heat hydraulic and lube oils, the HS is a fully self-contained heating and filtration solution ideal for service applications, mass fluid transfers, and preheating systems before they come online.

Completely customizable for hydraulic fluids and high viscosity lubrication oils up to ISO VG 680.



Fluid Conditioning Equipment

Diesel Filter Housings & Systems

COD

Diesel Conditioning Systems

Remove water and particulate to extend fuel injector life and increase combustion engine fuel efficiency.

Ideal for large mining and construction fueling depots, diesel fueled turbines, backup generators, and smaller day tank dispensing or on-board fueling truck applications. With options for adding non-powered units to existing fuel dispensing lines, there's a perfect COD for all of your diesel applications.



FSLCOD

Marine and Industrial Diesel Filtration Systems

Remove water and particulate to extend fuel injector life and increase combustion engine fuel efficiency.

Ideal for permanent installation on-board sea vessels and diesel applications requiring compact size restrictions.

FCLCOD

Diesel Conditioning Filter Cart

Remove water and particulate to extend fuel injector life and increase combustion engine fuel efficiency.

Ideal for service oriented stand by diesel tanks and marine applications.



CSD

Diesel Coalesce Non-Powered Filtration System

Remove water to extend fuel injector life and increase combustion fuel efficiency. The CSD is designed for direct integration into fuel delivery systems with pump flow and pressure already in place for easy, streamlined water removal through your existing system. Using high efficiency coalesce and separating media, the CSD will keep diesel free from water contamination down to 50 ppm in a single pass.

Ideal for construction fueling depots, tank farms and common fuel rail applications.

Fluid Conditioning Equipment

Varnish & Acid Scavenging Systems

FSA

Phosphate Ester Conditioning Systems

A complete solution for trouble-free EHC operation using phosphate ester fluids. Avoid premature fluid replacement, bleed and feed, and eliminate expensive flushes. FSAPE is the new standard for maintenance of water, acid, ISO Code, resistivity, and removal of gels and deposits that cause servo valve failure.

Ideal for steam turbine EHC fire resistant fluid maintenance.



FSJL

Aeroderivative Jet Lube Oil Conditioning Systems

FSJL fluid conditioning skids are a total solution for managing aeroderivative jet lube oils susceptible to high thermal oxidative stress and coke deposit formation. FSJL prevents and reduces coke deposits that lead to variable geometry failures. Extend useful fluid life by removing the catalysts for oxidation; O₂ contact, acid, oxidative coking precursors, dissolved metals, combustible gases, water, and varnish all while maintaining low ISO Codes. Specifically designed for MIL-L-23699 aeroderivative jet lube oils, the FSJL eliminates the contamination that leads to variable geometry failures.

Ideal for maintenance of aeroderivative jet lube oil and hydraulic systems.

FSTO

Turbine Oil Varnish Removal Systems

FSTO is the complete oil conditioning solution for turbine and compressor lube oil. FSTO treats both soluble and insoluble forms of oxidation by-products to remove and prevent varnish deposits and deliver guaranteed results.

Utilizing ICB®'s patented ion-exchange resin technology, FSTO removes the soluble varnish feedstock, acids and protects the anti-oxidant additive package while VTM high efficiency post filter removes insoluble by-products and will deliver unimaginably low ISO cleanliness codes so you can use your clean, in-service oil longer than ever before.



ECR[®]

Particulate Removal System

Ideal for sub-micron insoluble contamination removal in phosphate ester fluids in turbine EHC systems.

Remove fine particulates that are below the range of mechanical filters. Standard Electrostatic Oil Cleaner (EOC) systems are ineffective for phosphate ester fluid applications due to fluid conductivity restrictions. The ECR[®] is designed specifically to solve this dilemma.



ICB[®]

Ion-Exchange Filters

While offering best in class acid and varnish removal, ICB[®] filter elements significantly reduce production losses and resolve servo-valve issues by eliminating the contamination responsible for sticking or sluggish valves. Conventional acid filters cannot remove this contamination and are also significant contributors of harmful metals and fine particulate. ICB[®] filters eliminate these key issues and direct maintenance to where it matters most.



SVR®

Lubricant Conditioning System

A complete recovery and maintenance solution for turbine lubricants. SVR® targets and removes the dissolved varnish pre-cursors which are the cause of varnish. By removing these waste oxidation by-products, you restore the oils original solvency properties which forces any solid varnish deposits to be dissolved back into the oil where they are removed permanently.



Fluid Conditioning Equipment

Water Removal Systems

COT

Turbine Oil Conditioning Skids

Remove harmful particulate and water contamination and achieve target ISO Codes faster with the COT.

Ideal for preventing unplanned downtime and premature component failures in turbine lube systems.



V1

Compact VUD Vacuum Dehydrator

A compact and mobile dehydration and high efficiency filtration solution, the V1 prevent acidity and loss of lubrication properties caused by inefficient dehydration and high ingestion.

Ideal for rapidly removing all forms of water including free, emulsified, and dissolved water and gas from hydraulic and lube oils.

VUD

Vac-U-Dry Vacuum Dehydrators

The optimized balance between heat, vacuum, process design and an easy, user friendly operating system for removal of water and particulate from hydraulic and high viscosity lubricating oils. Equipped with generously sized, high efficiency filtration, the VUD is the ultimate oil purifier.

Keeping fluids clean and dry extends component and bearing life, increases productivity, minimizes downtime and extends useful fluid life. The VUD is ideal for removal of all forms of water, including free, emulsified and dissolved water and gas from hydraulic and lubricating oils.



TMR®- Air

Water Removal System

TMR®-Air systems cost effectively remove all 3 forms of water from lubricants and hydraulic fluids through mass transfer which is a highly effective, non-mechanical process. Using TMR®-Air exploits the principle of chemical equilibrium in a gentle, energy efficiency method.



FCLCOT

Turbine Oil Conditioning Filter Cart

A mobile solution that maintains turbine lube oil by removing water and particulate contamination that can cause corrosion, fluid breakdown, abrasive wear on components, additive precipitation, reduced lubricity, and dielectric strength loss.

Ideal for turbine lube oil, boiler feed pumps, compressors and others R&O applications.

TMR[®] - N₂

Water Removal System

Total Water Removal Nitrogen systems (TMR[®]-N₂) cost effectively remove all 3 forms of water from lubricants and hydraulic fluids through mass transfer which is a highly effective, non-mechanical process. TMR[®]-N₂ generates a constant flow of high purity N₂ which is injected into the head space of the lubricant reservoir to remove and maintain very low water levels.



Fluid Conditioning Equipment

Fluid Handling + Storage

LCS

Liquid Conditioning Station

Begin filtration and contain contamination before it ever enters your plant to protect your equipment and your bottom line. Built with your convenience in mind and completely customizable for size and fluids, the LCS is a complete contamination solution for hydraulic and lube oil storage and handling.

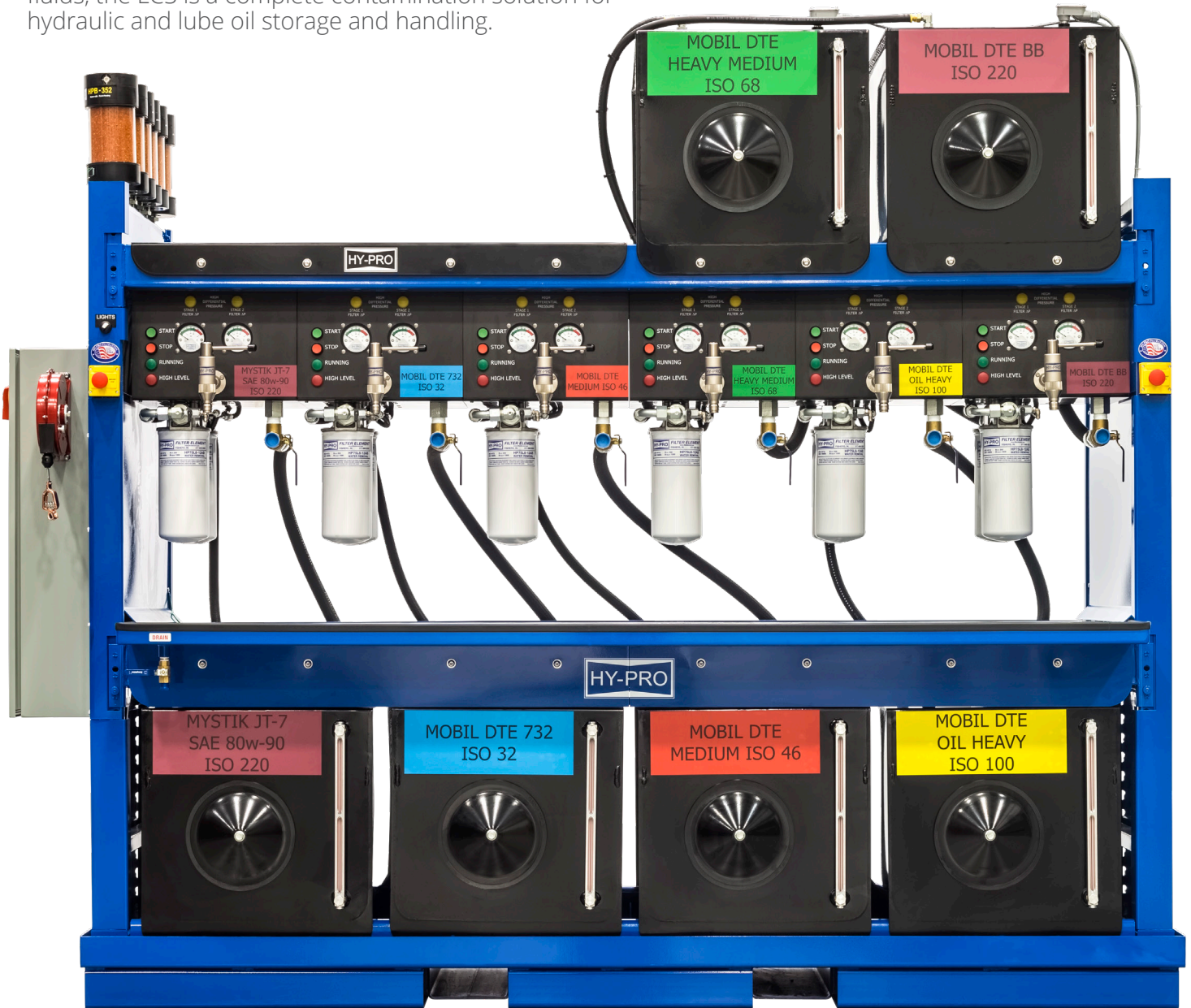

Custom Equipment

Application based contamination solutions tailored to meet your exact needs and exceed your expectations.

Call Hy-Pro for more information.





Hy-Pro Interchange

The world's largest selection of critical filter elements.

With over 250,000 filter element crosses, Hy-Pro's Interchange offers the most extensive and comprehensive selection of critical hydraulic and lube oil filter elements anywhere. And it's only growing larger. Each year, we catalog thousands of filter elements in our efforts to provide our customers with the best contamination solutions, service and support possible.

ISO Certification



American Systems Registrar, LLC, a provider of third-party system registration and accredited by the ANSI National Accreditation Board attests that:

HY-PRO CORPORATION
6810 LAYTON ROAD
ANDERSON, IN 46011

with a scope of:

DESIGN AND MANUFACTURE OF FLUID FILTRATION COMPONENTS AND SYSTEMS

has established a quality management system that is in conformance with the International Quality System Standard

ISO 9001:2015

ASR Certificate Number: 1459
Date of Certification: July 17, 2021
Date of Certification Expiration: July 16, 2024
Revision:
Re-Issue Date:

President

CERTIFICATE OF REGISTRATION

Want to find out more? Get in touch.

hyprofiltration.com

info@hyprofiltration.com

+1 317 849 3535

© 2023 Hy-Pro Corporation. All rights reserved.



MKTLIT-GEN-013023-EM